

PRODUCT SPECIFICATIONS

Remote type, electric refrigerated water chiller unit. Chilling Capacity of 1.0 GPH (gallons per hour) of 50° F drinking water, based on 80° F inlet water and 90° F ambient, per ASHRAE 18 testing. Installs directly under fountain or other application, or may be located in a service area to serve a remote outlet (within 15 feet recommended). Unit shall be certified to UL 399 and CAN/CSA C22.2 No. 120. Unit shall be lead-free design which is certified to NSF/ANSI 61 & 372 (lead free) and meets Federal and State low-lead requirements. Can be used with reverse osmosis filtered water, contains stainless steel tank and waterways.

Compact, highly efficient water chiller units are designed for use with any drinking fountain. Also connects to a bubbler, glass filler or cold water dispenser. Converts a fountain into a water cooler.

Finish:	Galvanized Steel
Power:	115V/60Hz
Chilling Capacity*:	1.0 GPH
Rated Watts:	140
Dimensions:	17" x 7" x 14"
Approx. Shipping Weight:	33 lbs.
Installation Location:	Indoor
No. of Stations Served:	1
*Based on 80° F inlet water & 90° F ambient air temp for 50° F chilled drinking water.	

CONSTRUCTION

- Cabinet: Rust-resistant galvanized steel

COOLING SYSTEM

- Compressor: Hermetically-sealed, reciprocating type, single phase. Sealed-in lifetime lubrication.
- Condenser: Fan cooled, copper tube with aluminum fins. Fan motor is permanently lubricated.
- Cooling Unit: Combination tube-tank type. Continuous copper tubing is fully insulated with foam that meets UL requirements for self-extinguishing material.
- Refrigerant Control: Refrigerant R134a is controlled by accurately calibrated capillary tube.
- Temperature Control: Easily accessible enclosed adjustable thermostat is factory preset. Requires no adjustment other than for altitude requirements.



AMERICAN PRIDE. A LIFETIME TRADITION. Like your family, the Elkay family has values and traditions that endure. For almost a century, Elkay has been a family-owned and operated company, providing thousands of jobs that support our families and communities.



Included with Product: Water Chiller

PRODUCT COMPLIANCE

Buy American Act
CAN/CSA C22.2 No. 120
NSF/ANSI 61 & 372 (lead free)
UL 399



[Installation Instructions \(PDF\)](#)

5 Year Limited Warranty on the refrigeration system of the unit. Electrical components and water system are warranted for 12 months from date of installation. **Warranty pertains to drinking water applications only. Non-drinking water applications are not covered under warranty.**

[Warranty \(PDF\)](#)

PART: _____ QTY: _____

PROJECT: _____

CONTACT: _____

DATE: _____

NOTES: _____

APPROVAL: _____

In keeping with our policy of continuing product improvement, Halsey Taylor reserves the right to change product specifications without notice. Please visit Halseytaylor.com for the most current version of Halsey Taylor product specification sheets. This specification describes a Halsey Taylor product with design, quality, and functional benefits to the user. When making a comparison of other producers' offerings, be certain these features are not overlooked.

Operating Pressures:

Supply water - recommended water pressure range is 40-105 psi

NOTE: A service stop (not included) should be installed at the chiller inlet line.

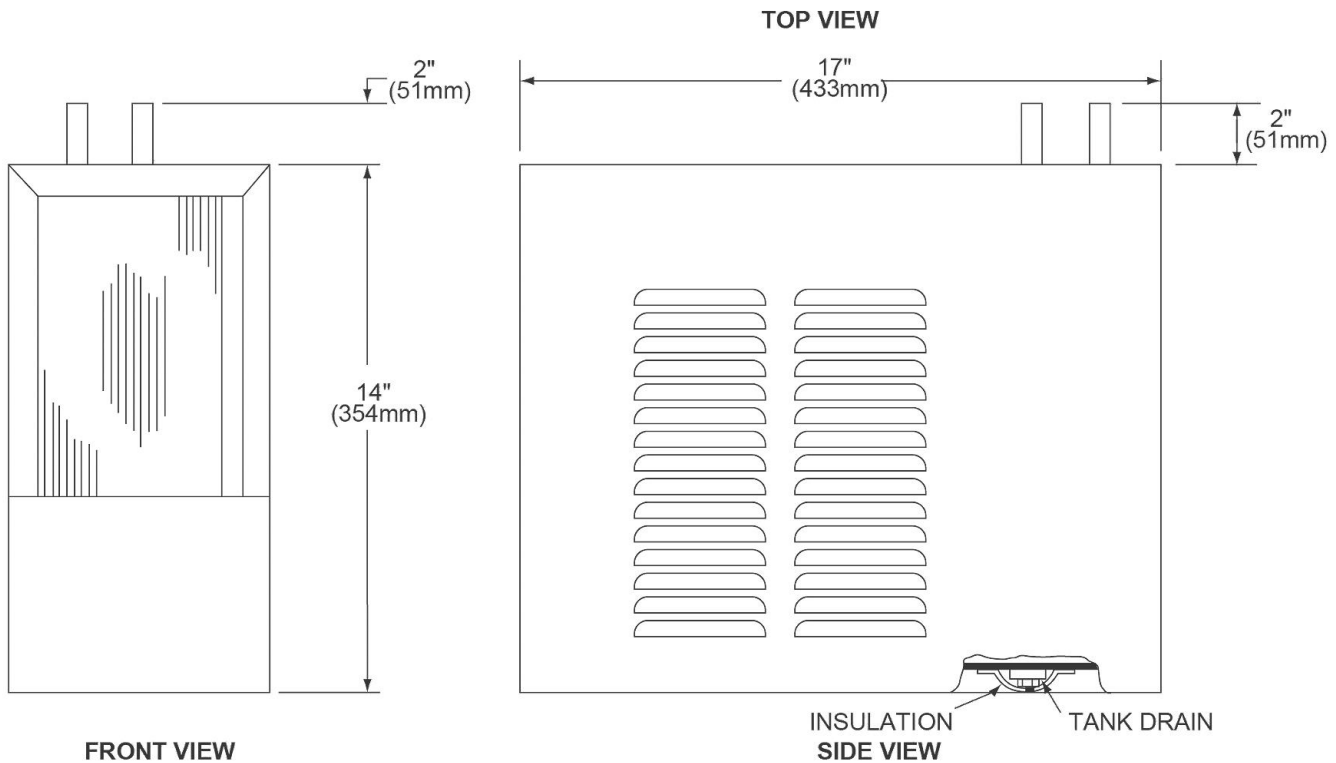
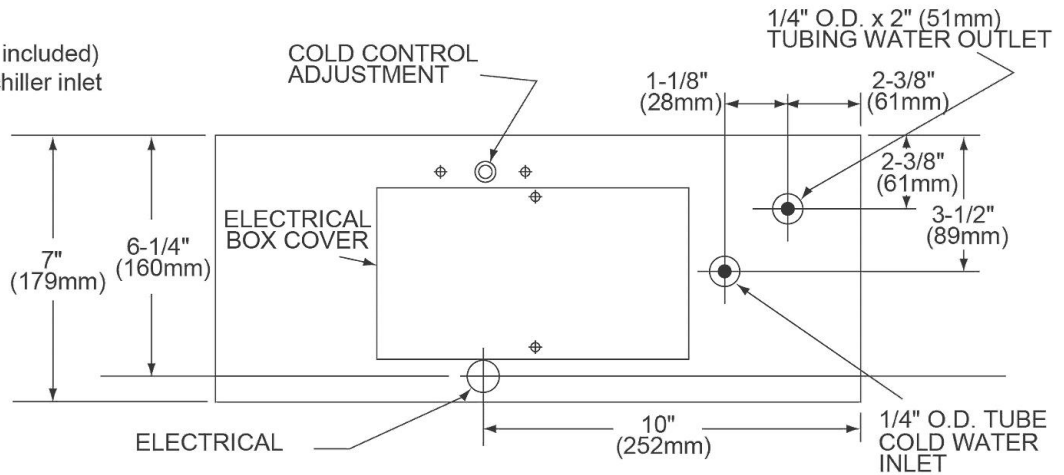

NOTE: It is important to insure proper ventilation. If this remote chiller is physically placed against barrier or in enclosure of any kind, 4" (102mm) air space must be allowed on all sides.

In keeping with our policy of continuing product improvement, Halsey Taylor reserves the right to change product specifications without notice. Please visit Halseytaylor.com for the most current version of Halsey Taylor product specification sheets. This specification describes a Halsey Taylor product with design, quality, and functional benefits to the user. When making a comparison of other producers' offerings, be certain these features are not overlooked.